

AXOR[®]

hansgrohe

- EN** Installation / User Instructions / Warranty
- FR** Instructions de montage / Mode d'emploi / Garantie
- ES** Instrucciones de montaje / Manejo / Garantía

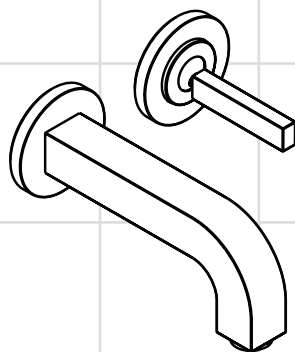

Citerio
39116xx1



C
A112.18.1-2005
CSA B125.1-2005
ICC/ANSI A117.1

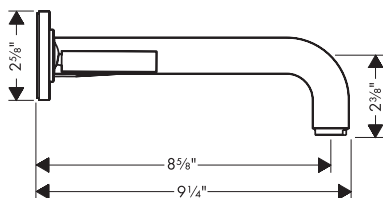
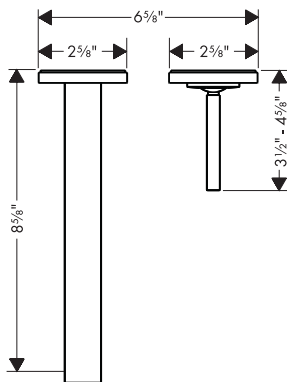

Tools Required / Outils Utiles / Herramientas Útiles

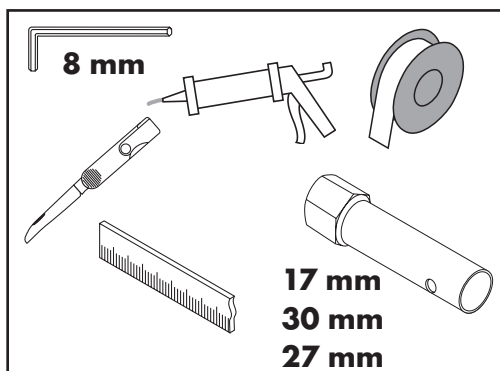

English

Technical Information

Recommended water pressure	15 - 75 PSI
Max. water pressure	145 PSI
Recommended hot water temp.	120° - 140° F*
Max. hot water temp	176° F*
Flow rate	1.5 GPM

*Please know and follow all applicable local plumbing codes when setting the temperature on the water heater.

Installation Considerations

- For best results, Hansgrohe recommends that this unit be installed by a licensed, professional plumber.
- Please read over these instructions thoroughly before beginning installation. Make sure that you have all tools and supplies needed to complete the installation.
- This faucet requires rough 13622181 (not included). The rough must be installed and the finished wall completed and made watertight before installation of the trim kit.



This trim is not compatible with old-style rough 38111181.

- **If rough 38111181 is already installed, please contact Hansgrohe Technical Service regarding the additional parts and special instructions necessary to install this trim kit.**
- Keep this booklet and the receipt (or other proof of date and place of purchase) for this product in a safe place. The receipt is required should it be necessary to request warranty parts.

Français

Données techniques

Pression d'eau recommandée	15 - 75 PSI
Pression d'eau maximum	145 PSI
Température recommandée d'eau chaude	120° - 140° F*
Température maximum d'eau chaude	176° F*
Capacité nominale	1.5 GPM

* Vous devez connaître et respecter tous les codes de plomberie locaux applicables pour le réglage de la température du chauffe-eau.

À prendre en considération pour l'installation

- Pour de meilleurs résultats, Hansgrohe recommande que ce produit soit installé par un plombier professionnel licencié.
- Veuillez lire attentivement ces instructions avant de procéder à l'installation. Assurez-vous de disposer de tous les outils et du matériel nécessaires pour l'installation.
- Cette pièce doit être utilisée avec la pièce de surface 13622181 (pas d'inclus). La pièce de surface doit être installée et la surface du mur fini doit être terminée et étanche.



Cette pièce ne peut pas être utilisée avec la pièce intérieure obsolète 38111181.

- **Si la pièce intérieure 3811181 a été déjà installée, s'il vous plaît contactez Hansgrohe Technical Service pour les parties et les instructions supplémentaires.**
- Conservez ce livret et le reçu (ou une autre preuve sur laquelle figurent la date et l'endroit de l'achat) pour ce produit dans un endroit sûr. Le reçu est requis si vous commandez des pièces sous garantie.

Español

Datos técnicos

Presión recomendada en servicio	15 - 75 PSI
Presión en servicio max.	145 PSI
Temperatura recomendada del agua caliente	120° - 140° F*
Temperatura del agua caliente max.	176° F*
Caudal máximo	1.5 GPM

* Debe conocer y cumplir todos los códigos locales aplicables para ajustar la temperatura del calentador de agua.

Consideraciones para la instalación

- Para obtener mejores resultados, la instalación debe estar a cargo de un plomero profesional matriculado.
- Antes de comenzar la instalación, lea estas instrucciones detenidamente. Asegúrese de tener las herramientas y los insumos necesarios para completar la instalación.
- Esta pieza exterior es para usar con la pieza interior 13622181 (no incluidos). Debe instalarse la pieza interior y debe terminarse e impermeabilizarse la superficie del acabado de la pared.



Este pieza exterior no es compatible con la pieza interior al estilo antiguo 38111181.

- **Si la pieza interior 38111181 ya ha sido instalada, contacta por favor Hansgrohe Technical Service para partes e instrucciones adicionales.**
- Mantenga este folleto y el recibo (u otro comprobante del lugar y fecha de compra) de este producto en lugar seguro. El recibo se requiere en caso de ser necesario solicitar piezas bajo garantía.

Installation

 **Turn the water off at the main before proceeding.**

Remove the caps.

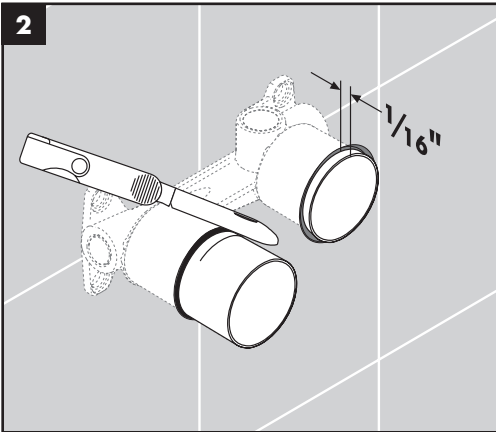
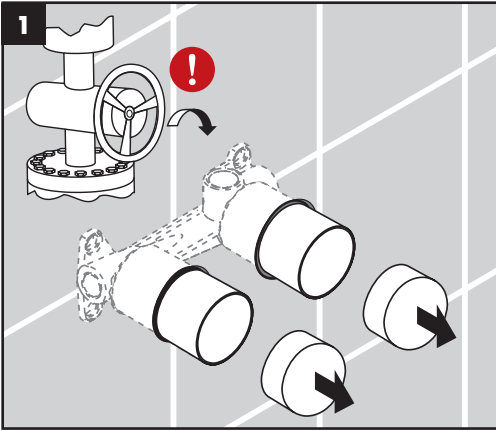

Cut the plaster shields so that they extend $\frac{1}{16}$ " outside the surface of the finished wall.

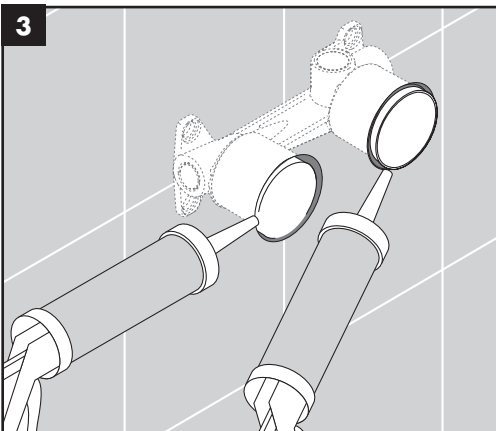

 **Seal the wall around the plaster shields using waterproof sealant.**

 **Failure to seal the wall can lead to possible water damage.**

Installation



Avant de commencer, fermez l'eau à la valve principale.

Retirez les capuchons.

Coupez les protecteurs de façon à ce qu'une partie de 1/16 po soit à l'extérieur de la surface du mur fini.



Scellez le mur autour des protecteurs à l'aide d'un agent d'étanchéité.



Si le mur n'est pas scellé, l'eau pourrait éventuellement causer des dommages.

Instalación



Cierre el paso del agua en la entrada del suministro antes de comenzar.

Retire las tapas.

Corte los protectores de yeso de modo que sobresalgan 1/16" de la superficie de la pared terminada.



Selle la pared alrededor del protector de yeso con un sellador impermeable.



Si no se sella la pared, pueden producirse daños por acción del agua.

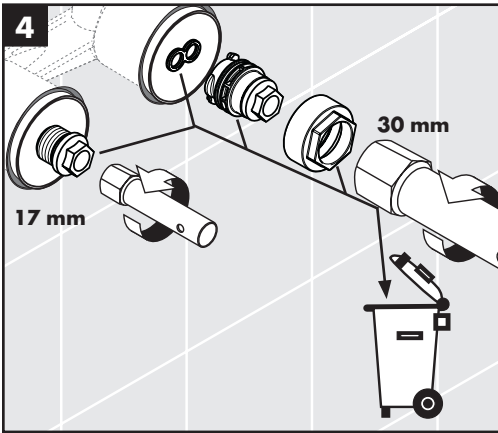

Remove the plug from the spout port.

Remove the nut, flush insert, and sealing ring from the cartridge port.

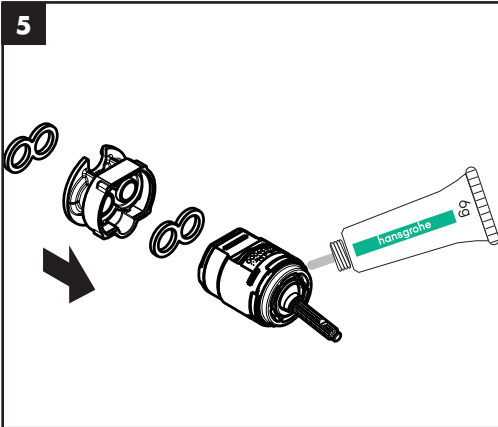

Install the cartridge adapter and sealing rings on the cartridge.

Lightly lubricate the cartridge o-ring using white plumbers grease.

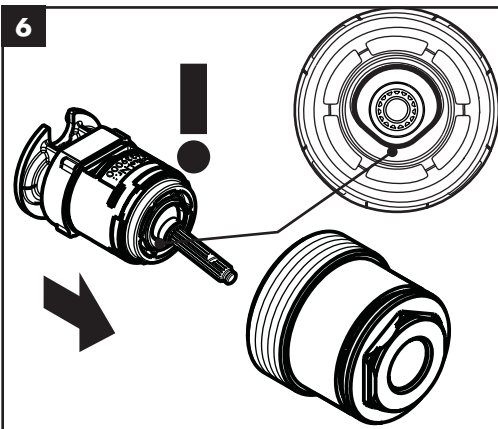

Insert the cartridge in the cartridge cover, oriented as shown on the diagram.

Français

Retirez le bouchon du port de bec de remplissage.

Retirez l'écrou, le compartiment affleurant et la bague d'étanchéité du port de cartouche.

Installez l'adaptateur et les bagues d'étanchéité dans la cartouche.

Lubrifiez légèrement la joint torique en utilisant de la graisse de plomberie blanche.

Insérez la cartouche dans la couverture de cartouche selon l'illustration.

Español

Retire el tapón del orificio del surtidor.

Retire la tuerca, el alojamiento de descarga y el anillo de sellado del orificio del cartucho.

Instale el adaptador y las juntas en el cartucho.

Lubrique levemente la junta toroidal con grasa blanca para plomería.

Inserte el cartucho en la cobertura de cartucho, orientado como mostrado en el esquema.

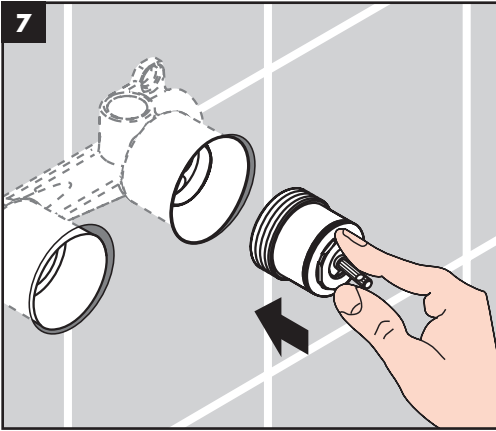

Install the cartridge.

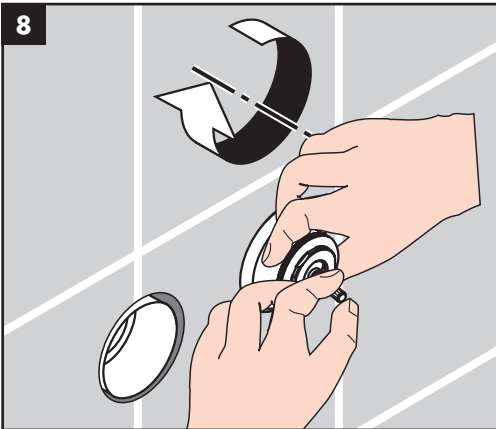

Hold the cartridge stem steady with one hand.
With the other hand, rotate the cover clockwise to secure it to the rough.

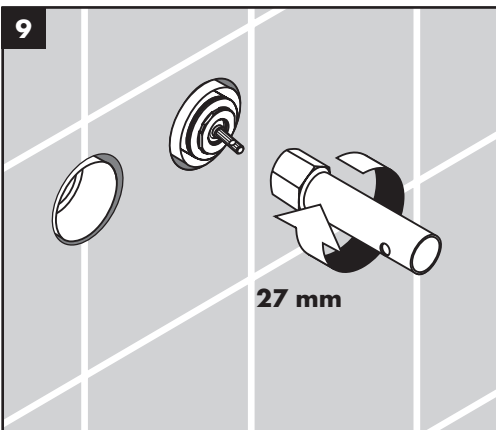

Tighten the cover using a 27 mm wrench.

Français

Installez la cartouche.

Tenez la cartouche en place avec une main.

Serrez le capot avec l'autre main.

Serrez la couverture à l'aide d'une clé de 27 mm.

Español

Instale el cartucho.

Tenga el cartucho en el lugar con una mano.

Apriete la cobertura con la otra mano.

Apriete la cobertura con una llave de 27 mm.

10

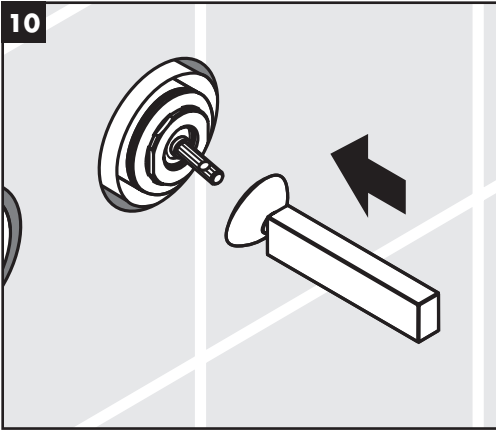

Install the handle.

11

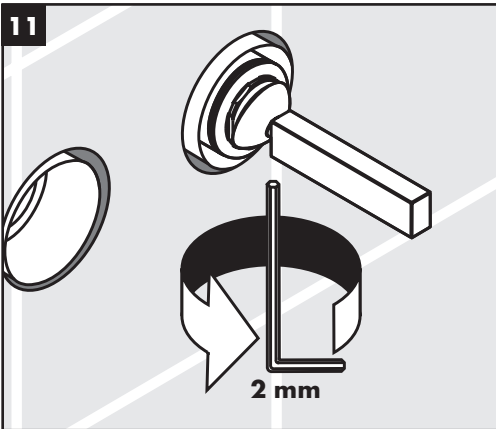

Tighten the handle screw using a 2 mm Allen wrench.

12

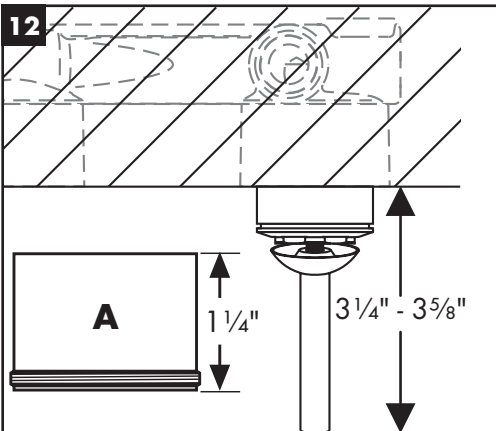

Measure the distance between the wall and the edge of the handle.

If the distance measures $3\frac{1}{4}'' - 3\frac{5}{8}''$, select sleeve A.

Français

Installez la poignée.

Installez la vis de la poignée à l'aide d'une clé hexagonale de 2 mm.

Mesurez la distance entre le mur et le rebord de la poignée.

Si la distance mesure de $3\frac{1}{4}$ po - $3\frac{5}{8}$ po, sélectionnez le gaine A.

Español

Instale la manija.

Apriete el tornillo con una llave Allen de 2 mm.

Mida la distancia entre la pared y el borde de la manija.

Si la distancia es de $3\frac{1}{4}$ " - $3\frac{5}{8}$ ", seleccione el manguito A.

If the distance measures $3\frac{5}{8}$ " - 4" select sleeve B.

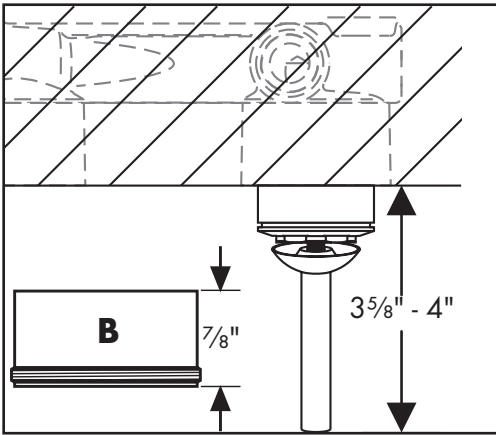

If the distance measures 4" - $4\frac{3}{8}$ ", select sleeve C.

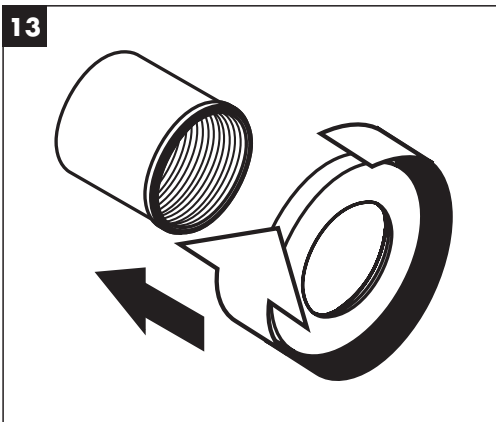
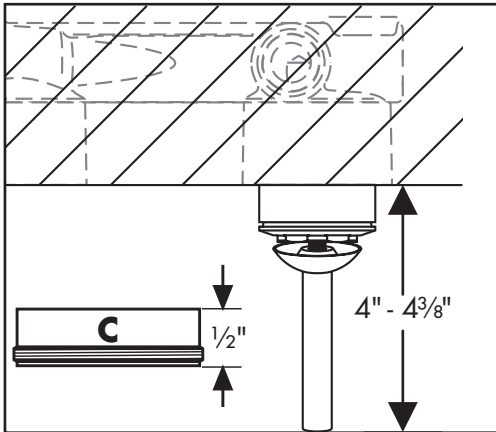

Connect the handle escutcheon to the selected sleeve.

Français

Si la distance mesure de $3\frac{5}{8}$ po - 4 po, sélectionnez le gaine B.

Si la distance mesure de 4 po - $4\frac{3}{8}$ po, sélectionnez le gaine C.

Raccordez l'écusson de la poignée à le gaine sélectionnée.

Español

Si la distancia es de $3\frac{5}{8}$ " - 4", seleccione el manguito B.

Si la distancia es de 4" - $4\frac{3}{8}$ ", seleccione el manguito C.

Conecte el embellecedor de la manija en el manguito seleccionado.

14

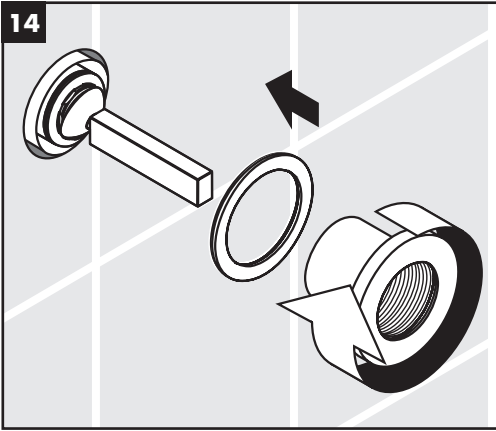

Install the washer and sleeve/escutcheon assembly.

15

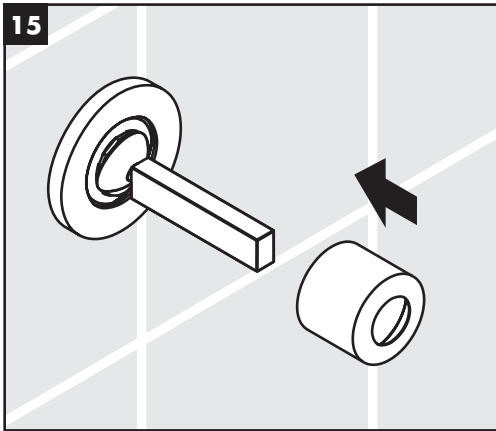

Install the flange.

16

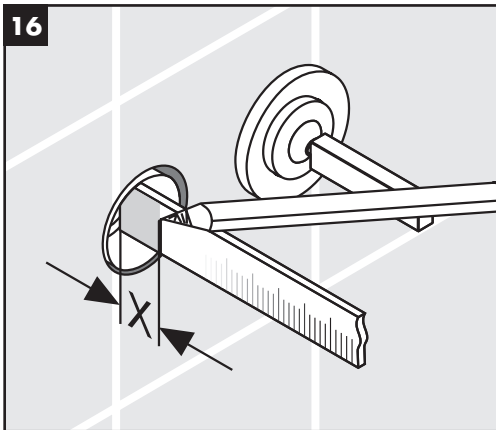

Measure the distance from the surface of the spout port rough to the outside edge of the plaster shield ("X").

Français

Installez l'assemblage gaine/écusson.

Español

Instale el manguito y los el embellecedor.

Installez la bride.

Instale la brida.

Mesurez la distance entre la surface de la pièce du port de bec de remplissage et le rebord extérieur du protecteur (« X »).

Mida la distancia desde la superficie de la parte interna del orificio del surtidor hasta el borde externo del protector de yeso ("X").

English

17

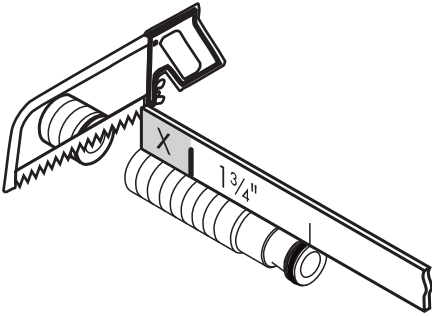

$X + 1\frac{3}{4}''$

Add $1\frac{3}{4}''$ mm to X.

Cut the threaded nipple so that it is $X + 1\frac{3}{4}''$ long.

18

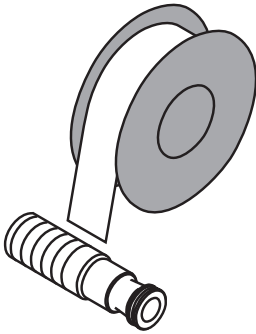

Wrap the threads on the nipple with Teflon tape.

19

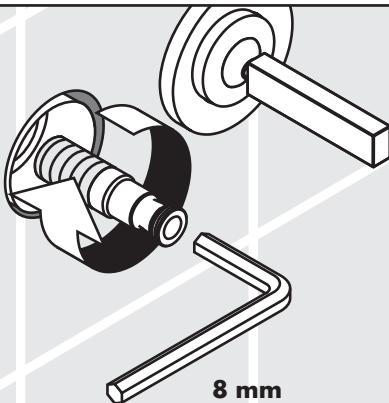

8 mm

Install the nipple.

Tighten the nipple using an 8 mm Allen wrench.

Français

Ajoutez 1¼ po à la mesure « X ».

Coupez le raccord fileté de façon à ce qu'il mesure « X » + 1¼ po de long.

Enveloppez les filets sur le raccord fileté avec du ruban Téflon.

Installez le raccord fileté.

Serrez le raccord fileté à l'aide d'une clé hexagonale de 8 mm.

Español

Agregue 1¼" mm a X.

Corte el niple roscado para que tenga X + 1¼" de largo.

Envuelva las roscas del niple con cinta de Teflon.

Instale el niple.

Apriete el niple con una llave Allen de 8 mm.

20

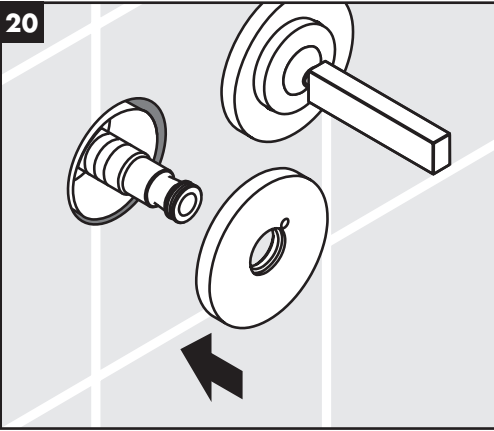

Install the spout escutcheon.

21

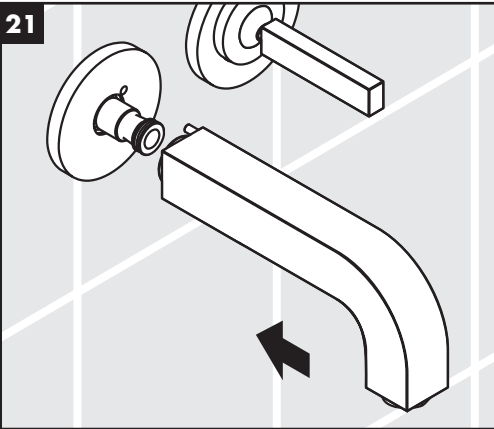

Push the spout into place over the nipple.

22

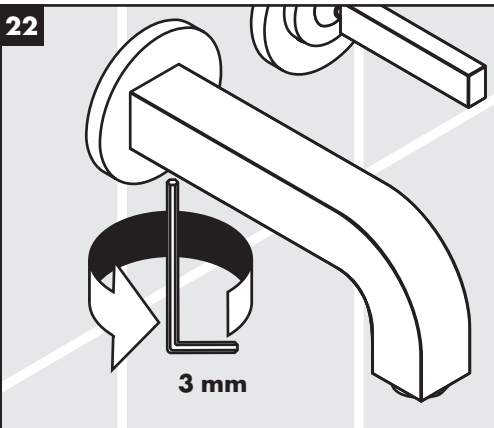

Tighten the spout screw using a 3 mm Allen wrench.

Français

Installez l'écusson du bec.

Poussez le bec de remplissage en place sur le raccord fileté.

Serrez la vis du bec à l'aide d'une clé hexagonale de 3 mm.

Español

Instale el embellecedor del surtidor.

Coloque el surtidor en su lugar sobre el niple.

Apriete el tornillo del surtidor con una llave Allen de 3 mm.

User Instructions / Instructions de service / Manejo

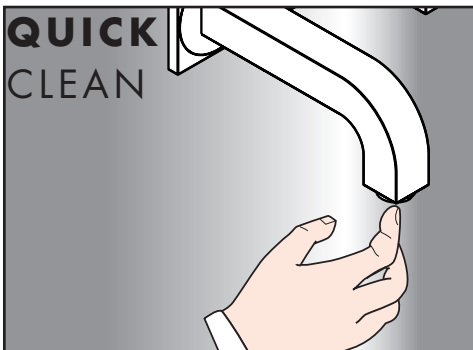
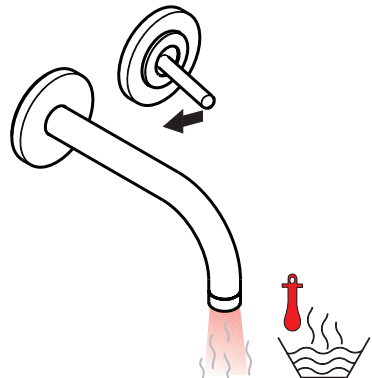
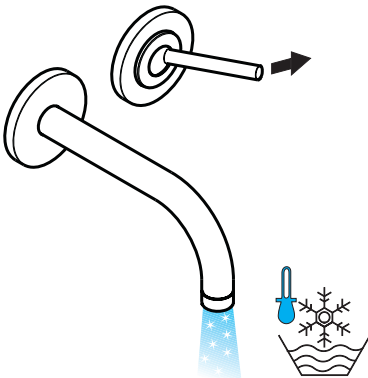
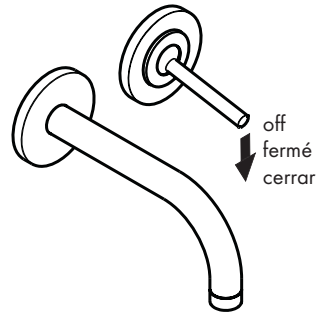
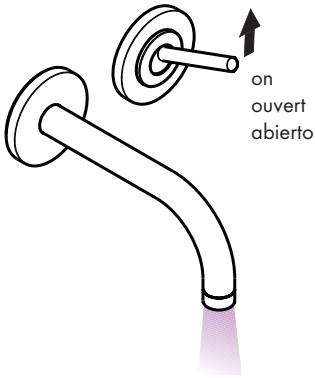

The aerator uses QuickClean cleaning system. Deposits of mineral scale can be removed by rubbing across the channels with a finger or sponge.

L'aérateur est équipée de QuickClean, le système anticalcaire manuel. Les dépôts de calcaire s'enlèvent en frottant avec un doigt ou avec une éponge sur les ouvertures de jets élastiques.

QuickClean, la función de limpieza manual, permite quitar la cal simplemente frotando los eyectores

Replacement Parts / Pièces détachées / Repuestos

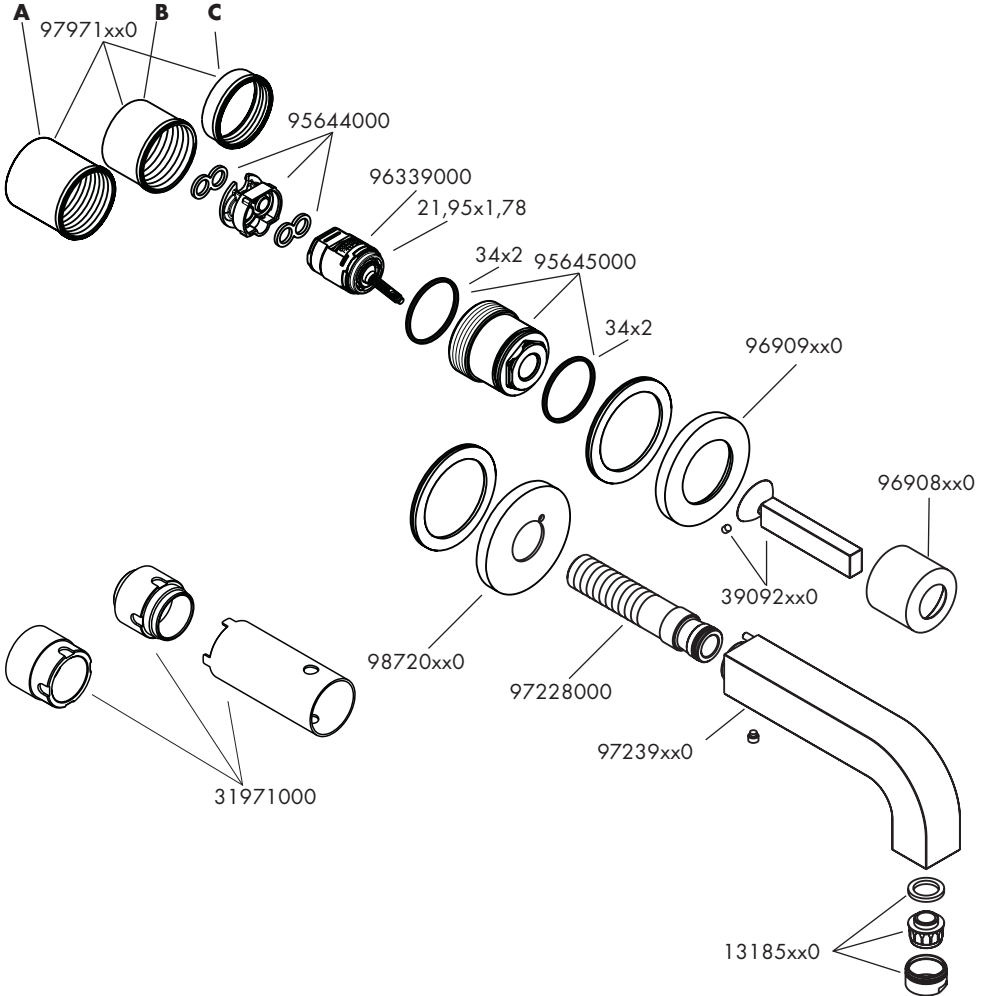

xx = colors / couleurs / acabados

00 = chrome

82 = brushed nickel

Cleaning Recommendation for Hansgrohe Products

Modern bathroom faucets, kitchen faucets and shower products are made from different materials to comply with the needs of the market with regard to design and functionality. To avoid damage to the product, it is necessary to take proper care of it.

For best results:

- Prevent the buildup of mineral scale and /or soap residue by cleaning your Hansgrohe product(s) when needed.
- Select a cleaning agent specifically intended for the type of product.
- **Do not** use these types of cleaners as they will cause damage to your Hansgrohe product:
 - ✘ Any cleaning agent containing hydrochloric acid, formic acid, lye, or acetic acid.
 - ✘ Abrasive cleaning powders, pads, or brushes.
 - ✘ Steam cleaners.
 - ✘ "No rinse" cleaning agents.
- **Always** follow the instructions provided by the manufacturer of the cleaning agent.
- **Do not** mix cleaning agents, unless directed by the manufacturer.
- **Do not** spray cleaners directly onto the product as drops could enter openings and gaps and cause damage. When using spray cleaners, spray the cleaner onto a soft cloth or sponge.
- **Always** rinse your Hansgrohe product thoroughly with clear water and polish dry with a soft cloth after cleaning.

Important

- Residue from soaps and shampoos can cause damage. Rinse the product with clean water after each use.
- Residue from basin/tub/tile cleaner can cause damage to faucets and fittings. Immediately rinse any overspray from the Hansgrohe product.
- **Damage to the product caused by improper care or the use of improper cleaning agents is not covered by the warranty.**
- **If a component of the product is damaged, replace it, as there is risk of injury.**

Conseil de nettoyage pour les produits Hansgrohe

De nos jours le sanitaire moderne, la robinetterie et les douchettes se composent de matériaux très différents pour satisfaire à la demande concernant le design et la fonctionnalité. Pour éviter les détériorations et les réclamations, aussi bien pour l'utilisation que pour le nettoyage prochain, certains critères seront à prendre en considération.

A prendre en considération lors de l'entretien de la robinetterie et de douchettes:

- On doit seulement utiliser les produits de nettoyage qui sont formellement prévus pour ce domaine.
- Aucun contact avec l'application de nettoyants contenant de l'acide chlorhydrique, de l'acide formique ou de l'acide acétique qui peuvent causer de considérables détériorations.
- Les nettoyants à base d'acide phosphorique, aussi, ne sont pas à utiliser sans réserves.
- Le mélange de nettoyants en général n'est pas autorisé.
- L'utilisation de produits de nettoyage récurants et des ustensiles comme des frottoirs, des éponges à récurer et des torchons microfibrés est exclue.
- Les conseils d'entretien des producteurs de nettoyants sont à suivre obligatoirement.
- Le nettoyage est à faire correspondre avec le dosage, le temps d'action, spécifique à l'objet et à la nécessité.
- Le dépôt de calcaire est évité par un nettoyage régulier.
- Pour le nettoyage avec produit vaporisé liquide, en aucun cas sur la robinetterie, mais au contraire aspergé sur le chiffon (torchon, éponge) et effectuer comme cela le nettoyage, car les aérosols peuvent pénétrer dans les ouvertures et fentes de la robinetterie et peuvent provoquer des détériorations.

- Après le nettoyage rincez avec suffisamment d'eau claire pour éliminer les restes de produits attachés.
- L'utilisation d'appareil de nettoyage à vapeur n'est pas autorisée, car les températures importantes peuvent détériorer les produits.

Indications importantes

- Les produits pour le corps comme les savons liquides, les shampooings ou les gels de douche peuvent causer des détériorations.
- Ici aussi on doit: Après l'utilisation rincer soigneusement les restes avec de l'eau.

Conseil de nettoyage

- **Les deteriorations imputables à un mauvais entretien ne peuvent être pris en considération par notre garantie.**
- Par l'action d'un nettoyeur sur les revêtements déjà endommagé il se produit une aggravation des dégâts.

Recomendación de limpieza para los productos de Hansgrohe

Hoy en día, las griferías de baño y de cocina así como duchas modernas se componen de materiales muy distintos para satisfacer las exigencias del mercado respecto al diseño y la funcionalidad. Para evitar daños y reclamaciones hay que tener en cuenta ciertos aspectos tanto en el uso como en su limpieza.

Para el cuidado de las griferías y las duchas en principio hay que seguir lo siguiente:

- Usar sólo detergentes previstos específicamente para este campo de aplicación.
- No aplicar detergentes que contengan ácido clorhídrico, fórmico o acético porque pueden causar daños importantes.
- Detergentes que contienen ácido fosfórico tampoco pueden ser aplicados ilimitadamente. Por regla general no se deben mezclar detergentes.
- Tampoco se deben utilizar utensilios abrasivos, como son polvos abrasivos, esponjas o paños de microfibra.
- Se tienen que seguir siempre las sugerencias de empleo de los fabricantes de los detergentes.
- La limpieza tiene que ser realizada según la dosificación y el tiempo de actuación, en función del objeto y ajustada a las necesidades específicas del mismo.
- Gracias a una limpieza periódica se pueden evitar los depósitos de cal.
- No conviene rociar el detergente en ningún caso sobre la grifería sino sobre los textiles y ejecutar la limpieza así, porque el líquido puede entrar en aperturas o hendiduras de la grifería y causar daños.
- Después de la limpieza hay que aclarar con suficiente agua para eliminar completamente el resto de detergente.
- La utilización de limpiadores a vapor no está permitida, las altas temperaturas pueden dañar los productos.

Indicaciones importantes

- Los residuos de productos de aseo como jabón líquido, champú y gel de ducha pueden dañar también los materiales.
- Por lo que también se deberá prestar atención a lo siguiente: aclarar con abundante agua después del uso.
- Con materiales ya dañados la acción de detergentes incrementará el desgaste de estos.
- **Los componentes con superficies dañadas deberán cambiarse, en otro caso se corre el peligro de lesionarse.**
- Los daños que resulten de un uso inadecuado no están incluidos en nuestra garantía.

Limited Consumer Warranty

This product has been manufactured and tested to the highest quality standards by Hansgrohe, Inc. ("Hansgrohe"). This warranty is limited to Hansgrohe products that are purchased by a consumer in the United States or Canada after March 1, 1996, and installed in either in the United States or in Canada.

WHO IS COVERED BY THE WARRANTY

This warranty extends to the original purchaser only. This warranty is non-transferable.

WHAT IS COVERED BY THE WARRANTY

The warranty covers only your Hansgrohe manufactured product. Hansgrohe warrants this product against defects in material or workmanship as follows:

Hansgrohe will replace at no charge for parts only or, at its option, replace any product or part of the product that proves defective because of improper workmanship and/or material, under normal installation, use, service and maintenance. If Hansgrohe is unable to provide a replacement and repair is not practical or cannot be made in timely fashion, Hansgrohe may elect to refund the purchase price in exchange for the return of the product.

LENGTH OF WARRANTY

Replacement or repaired parts of products will be covered for the term of this warranty, as stated in the following two sentences. If you are a consumer who purchased the product for use primarily for personal, family or household purposes, this warranty extends for as long as you own the product and the home in which the product is originally installed. If you purchased the product for use primarily for any other purpose, including, without limitation, a commercial purpose, this warranty extends only (i) for 1 year, with respect to Hansgrohe & Commercial products, and (ii) for 5 years, with respect to Axor products.

THIS WARRANTY DOES NOT COVER, AND HANSGROHE WILL NOT PAY FOR:

- A. Conditions, malfunctions or damage not resulting from defects in material or workmanship.
- B. Conditions, malfunctions or damage resulting from (1) normal wear and tear, improper installation, improper maintenance, misuse, abuse, negligence, accident or alteration; (2) the use of abrasive or caustic cleaning agents or "no-rinse" cleaning products, or the use of the product in any manner contrary to the product instructions; or (3) conditions in the home such as excessive water pressure or corrosion.
- C. Labor and other expenses for disconnection, deinstallation, or return of the product for warranty service (including but not limited to proper packaging and shipping costs), or for installation or reinstallation of the product.
- D. Accessories, connected materials and products, or related products not manufactured by Hansgrohe.
- E. Any Hansgrohe or Axor product sold for display purposes.
- F. Rubbed Bronze finish is subject to a 3-year limited warranty. Chrome and all PVD finishes are covered by the limited lifetime warranty.
- G. Hansgrohe Water Filtration System is subject to a 1-year limited warranty. Warranty does not include replacement filters.

TO OBTAIN WARRANTY PARTS OR INFORMATION

Contact your Hansgrohe retailer, or contact Technical Service at:

Hansgrohe, Inc.
1492 Bluegrass Lakes Parkway
Alpharetta, GA 30004
Toll-free 800-334-0455

In requesting warranty service, you will need to provide:

1. The sales receipt or other evidence of the date and place of purchase.
2. A description of the problem.
3. Delivery of the product or the defective part, postage prepaid and carefully packed and insured, to:

Hansgrohe, Inc.
1492 Bluegrass Lakes Parkway
Alpharetta, GA 30004
Toll-free 800-334-0455

When warranty service is completed, any repaired or replacement product or part will be returned to you postage prepaid.

EXCLUSIONS AND LIMITATIONS

REPAIR OR REPLACEMENT (OR, IN LIMITED CIRCUMSTANCES, REFUND OF THE PURCHASE PRICE) AS PROVIDED UNDER THIS WARRANTY IS THE EXCLUSIVE REMEDY OF THE PURCHASER. HANSGROHE NEITHER ASSUMES NOR AUTHORIZES ANY PERSON TO CREATE FOR IT ANY OTHER OBLIGATION OR LIABILITY IN CONNECTION WITH THIS PRODUCT. HANSGROHE SHALL NOT BE LIABLE TO PURCHASER OR ANY OTHER PERSON FOR ANY INCIDENTAL, SPECIAL OR CONSEQUENTIAL DAMAGES, ARISING OUT OF BREACH OF THIS WARRANTY OR ANY IMPLIED WARRANTY (INCLUDING BUT NOT LIMITED TO ANY IMPLIED WARRANTY OF MERCHANTABILITY).

Some States do not allow the exclusion or limitation of incidental or consequential damages, so the above limitation or exclusion may not apply to you. This warranty gives you specific legal rights, and you may also have other rights that vary from state to state.

TO THE EXTENT PERMITTED BY LAW, ANY IMPLIED WARRANTIES OF MERCHANTABILITY AND FITNESS FOR A PARTICULAR PURPOSE, ARE LIMITED TO THE DURATION OF THE EXPRESS WARRANTY.

Some states do not allow limitations on how long an implied warranty may last, so the above limitations may not apply to you. You may be required by law to give us a reasonable opportunity to correct or cure any failure to comply before you can bring any action in court against us under the Magnuson-Moss Warranty Act.

PRODUCT INSTRUCTIONS AND QUESTIONS

Upon purchase or prior to installation, please carefully inspect your Hansgrohe product for any damage or visible defect. Prior to installing, always carefully study the enclosed instructions on the proper installation and the care and maintenance of this product. If you have questions at any time about the use, installation or performance of your Hansgrohe product, or this warranty, please write us or call us toll-free at 800-334-0455.

hansgrohe

Hansgrohe, Inc. • 1490 Bluegrass Lakes Parkway • Alpharetta, GA 30004
Tel. 770-360-9880 • Fax 770-360-9887

www.hansgrohe-usa.com